

Type XTSR71
Sizes 494-5258**Figure 1 – Thomas XTSR71 Coupling****1. General Information**

- 1.1 Rexnord Thomas Couplings are designed to provide a mechanical connection between the rotating shafts of mechanical equipment, using flexible discs to accommodate inherent misalignment while transmitting the power and torque between the connected shafts.
- 1.2 These instructions are intended to help you to install and maintain your Rexnord Thomas coupling. Please read these instructions prior to installing the coupling, and prior to maintenance of the coupling and connected equipment. Keep these instructions near the coupling installation and available for review by maintenance personnel. For special engineered couplings, Rexnord may provide an engineering drawing containing installation instructions that take precedence over this document.
- 1.3 Rexnord owns the copyright of this material. These Installation and Maintenance instructions may not be reproduced in whole or in part for competitive purposes.
- 1.4 Symbol descriptions:

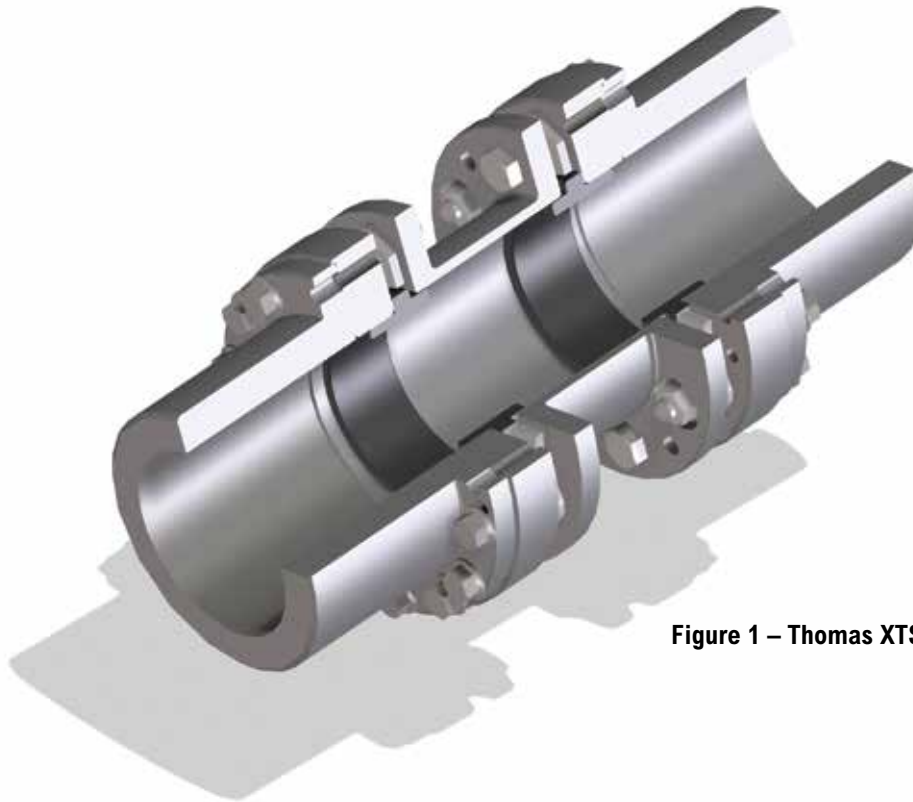

Danger of injury to persons.



Damages on the machine possible.



Pointing to important items.



Hints concerning explosion protection.

2. Safety and Advice Hints



DANGER!

- 2.1 Safety should be a primary concern in all aspects of coupling installation, operation and maintenance.
- 2.2 Do not make contact with the coupling when it is rotating and/or in operation.
- 2.3 Because of the possible danger to person(s) or property from accidents which may result from improper use or installation of these products, it is extremely important to follow the proper selection, installation, maintenance and operational procedures.
- 2.4 Installation should be carried out by skilled personnel only. All personnel involved in the installation, service, operation, maintenance, and repair of this coupling and the connected equipment must read, understand, and comply with these Installation and Maintenance instructions. The Installation and Maintenance instructions and assembly drawing, if provided, must be at hand at the installation site.



PRECAUTION

For this coupling to meet the ATEX requirements, you must precisely follow these installation and maintenance instructions, and the supplement form 0005-08-49-01. This supplement outlines the ATEX requirements. If the operator does not follow these instructions, the coupling will immediately be considered non-conforming to ATEX.

- 2.5 All rotating power transmission products are potentially dangerous and can cause serious injury. They must be properly guarded in compliance with OSHA, ANSI, ATEX, European machine safety standards and other local standards. It is the responsibility of the user to provide proper guarding.
- 2.6 The coupling should be stored in a dry corrosion protected environment, free from external loads (for example by stacking) to prevent damage which may cause a hazard when the coupling is put into service.
- 2.7 For ATEX requirements the guard must have a minimum of 12.7 mm (1/2 in) radial clearance to the coupling outside diameter and allow for proper ventilation.
- 2.8 All conductive parts of the equipment should be connected in such a way that hazardous electrical potential differences cannot occur. In case insulated metal parts could be charged thus becoming a potential ignition source, earth connections must be provided.
- 2.9 Make sure to disengage the electrical power and any other sources of potential energy before you perform work on the coupling.
- 2.10 Packaging material can generate electrostatic charges. It may then become an explosive hazard. It must be removed from the coupling outside any hazardous areas.
- 2.11 Proper lockout-tag out procedures must be followed to safeguard against unintentional starting of the equipment.
- 2.12 All work on the coupling must be performed when the coupling is at rest with no load.
- 2.13 Do not start or jog the motor, engine, or drive system without securing the coupling components. If the equipment is started with only a hub attached, the hub must be properly mounted and ready for operation, with the key and set screw (if included) fastened. When the full coupling assembly is started, all fasteners and hardware must be completely and properly secured. Do not run the coupling with loose fasteners.
- 2.14 Use explosive environment appropriate tools only, for more information see DIN EN 1127-1:2008:02, Annex A.
- 2.15 The coupling may only be used in accordance with the technical data provided in the Thomas disc coupling catalog. Customer modifications and alterations to the coupling are not permissible.
- 2.16 All spare parts for service or replacement must originate from or be approved by Rexnord.

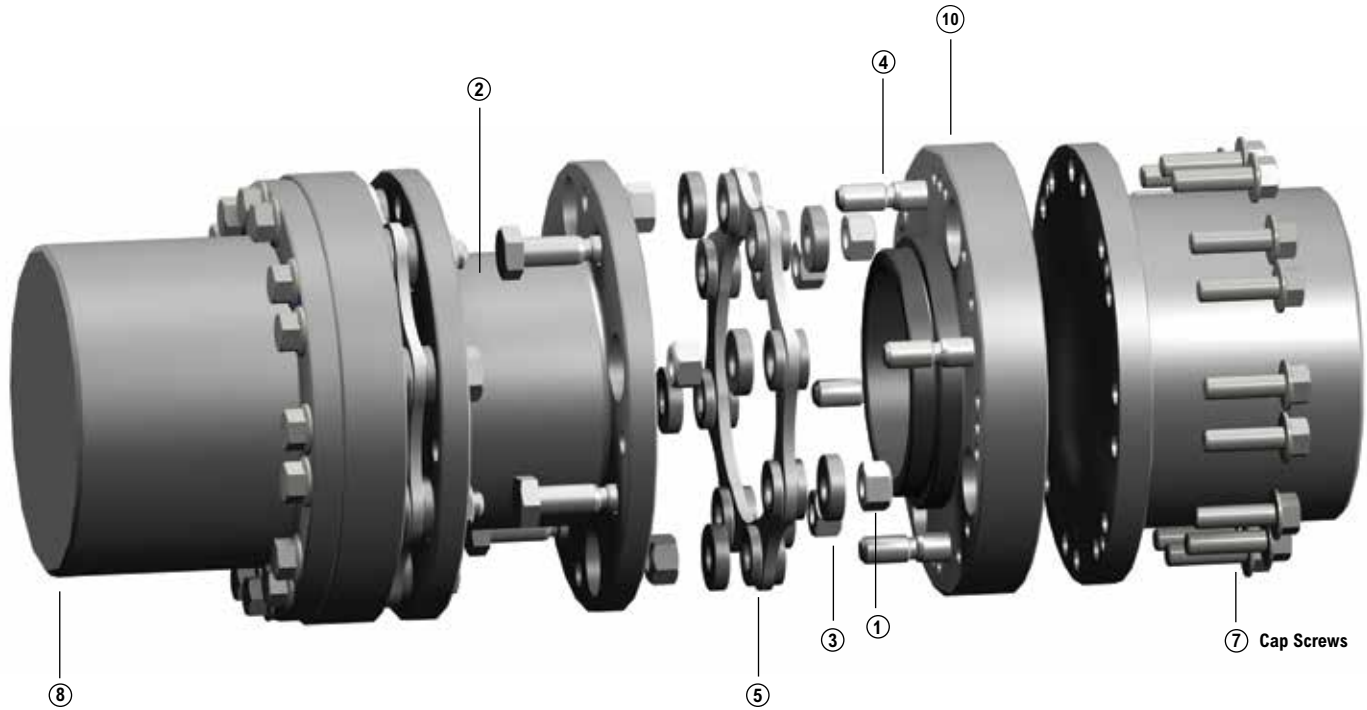
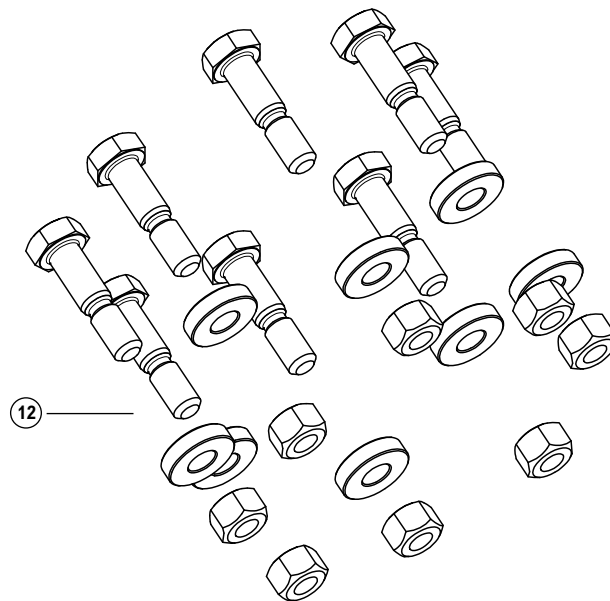

Figure 2 – Thomas XTSR71 Coupling Components



Note: Coupling component numbers above correspond to the component numbers in the column headers of Table 1.



**Figure 3 – Disc Pack Hardware Kit
Consisting of parts ①, ③ and ④ above.**

Thomas XTSR71 couplings are delivered from the factory with a fully assembled center member consisting of a center spool, two adapters, disc packs, bolts, bushings and locknuts that have already been tightened at the factory to the torque specified in Table 5. The center member assembly is ready for field installation and it is recommended that you do not disassemble it unless you are replacing the disc packs. Cap screws will need to be installed and tightened during installation.

Table 1 — Rexnord Thomas XTSR71 Coupling Component part numbers

Note: the circled numbers identified in the column headers below, correspond to the coupling component numbers in Figures 2 and 3.

XTSR71 Coupling Size	Standard Hub + Cap Screw Kit Part No. ⁽⁸⁾ **	XL Hub + Cap Screw Kit Part No.	Standard Adapter ⁽¹⁰⁾ Part No. (2 per coupling)	XL Adapter	XXL Adapter	Center Spool (1 per Coupling) ⁽²⁾				Disc Pack 2 per Coupling Part No. ⁽⁵⁾	Hardware Kit (Bolts, Locknuts, and Overload Bushings) for One Disc Pack ⁽¹²⁾			
						Part No.	"C" Length (in)	Part No.	"C" Length (mm)		Hardware Kit Part No.*	Bolts Quantity ⁽⁴⁾	Locknuts Quantity ⁽¹⁾	Bushings Quantity ⁽³⁾
494	10611141	10611142	10003755	10003215	10003216	10003235	3.50	10003238	100	10003753	10611144	4	4	4
						10003236	3.75	10003239	140					
						10003237	5.00	---	---					
644	10611142	---	10003754	---	10003218	10003240	3.50	10003243	100	10002803	10611145	4	4	4
						10003241	3.75	10003244	140					
						10003242	5.00	---	---					
726	10001611	10001612	10001131	10001781	10002805	10000871	3.50	10000801	100	10000091	10001561	6	6	6
						10311913	3.75	10000860	140					
						10000872	4.38	---	---					
						10000873	5.00	---	---					
826	10001612	10001613	10001132	10001782	10002806	10355817	3.50	10000802	100	10000092	10001562	6	6	6
						10319474	3.75	10000861	140					
						10000875	4.38	---	---					
						10000876	5.00	---	---					
996	10001613	10001614	10001133	10001783	10002807	10613540	3.75	10000862	100	10000093	10001563	6	6	6
						10000877	4.38	10000803	140					
						10000878	5.00	---	---					
						10000879	7.00	10000863	180					
1088	10001614	10001615	10001134	10001784	10002808	10000880	5.00	10000804	140	10000094	10001564	8	8	8
						10000881	7.00	10000864	180					
1298	10001615	10001616	10001135	10001785	10002809	10000882	5.00	10000805	140	10000095	10001565	8	8	8
						10000883	7.00	10000865	180					
1548	10001616	10001617	10001136	10001786	10002810	10000885	---	---	250	10000096	10001566	8	8	8
1698	10001617	10001618	10001137	10001787	10002811	10000886	7.00	10000807	180	10000097	10001567	8	8	8
						---	---	10000868	250					
1928	10001618	10001619	10001138	10001788	10002812	10000887	7.00	10000808	180	10000098	10001568	8	8	8
						10000888	7.50	10000869	250					
						10000889	8.00	---	---					
2068	10001619	10001620	10001139	10001789	10002813	10000891	8.00	10000809	250	10000099	10001569	8	8	8
2278	10001620	10001621	10001140	10001790	10002814	10000892	8.00	10000810	250	10000100	10001570	8	8	8
2468	10001621	10001622	10001141	10001791	10002815	10000893	9.00	10000811	250	10000101	10001571	8	8	8
2698	10001622	10001623	10001142	10001792	10002816	---	---	10000812	250	10000102	10001572	8	8	8
2888	10001623	10001624	10001143	10001793	10002817	---	---	---	---	10000103	10001573	8	8	8
3058	10001624	10001631	10001144	10001794	10002818	---	---	---	---	10000104	10001574	8	8	8
3358	10001631	10001625	10001145	10001795	10002819	---	---	---	---	10000105	10001575	8	8	8
3668	10001625	10001626	10001146	10001796	10002820	---	---	---	---	10000106	10001576	8	8	8
3908	10001626	10001627	10001147	10001797	10002821	---	---	---	---	10000107	10001577	8	8	8
4178	10001627	10001628	10001148	10001798	10002822	---	---	---	---	10000108	10001578	8	8	8
4588	10001628	10001629	10001149	10001799	10002823	---	---	---	---	10000109	10001579	8	8	8
4918	10001629	10001630	10001150	10001800	---	---	---	---	---	10000110	10001580	8	8	8
5258	10001630	---	10001151	---	---	---	---	---	---	10000111	10001581	8	8	8

*Disc pack hardware sold as kits only.

**All hub part numbers are non bored and include adapter hub hardware kit.

3. Hub Mounting



DANGER!

Be sure to disengage the electrical power and any other sources of potential energy before you perform work on the hub and coupling assembly.

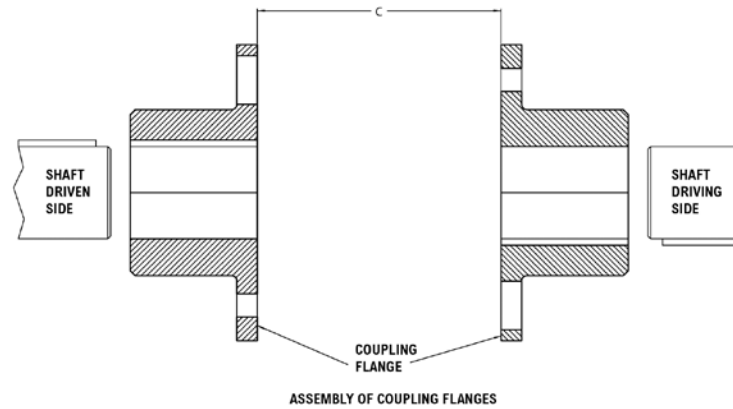

Figure 4 – Mounting Hubs on Shafts

- 3.1 Examine the coupling assembly to assure there is no visible damage.
- 3.2 Clean the hub bores and shafts using lint-free cloth. Remove any nicks or burrs.
- 3.3 The key(s) should have a close side-to-side fit in the keyway in the hub and shaft, with a slight clearance over the top when assembled.
- 3.4 Remove the cap screws that attach the hubs to the adapters, and remove both hubs.



Caution: When heating hubs is required, an oven is preferred and an open flame is not recommended. If flame heating is considered mandatory, it is important to provide uniform heating to avoid distortion and excessive temperature. A thermal stick applied to the hub surface will help determine the hub temperature.



DANGER!

Touching hot hubs causes burns. Wear safety gloves to avoid contact with hot surfaces.

4. Straight Bore with Clearance/Slip Fit

- 4.1 Install the key(s) in the shaft.
- 4.2 Check to be sure that the set screw(s) in the hub does not protrude into the keyway or the bore. Remove or back out the set screw to provide clearance during assembly.
- 4.3 Slide the hub up the shaft to the desired axial position.
- 4.4 If used; assemble and tighten the set screw(s) using a calibrated torque wrench to the values shown in Table 2.

Table 2 — Set Screw Tightening Torque

Set Screw Size		1/4-20	1/4-28	5/16-18	5/16-24	3/8-16	3/8-24	1/2-13	1/2-20
Hex Head Key Size		1/8	1/8	5/32	5/32	3/16	3/16	1/4	1/4
Tightening torque	(Nm)	7	9	15	16	27	31	68	75
	(lb-in)	66	76	132	144	240	276	600	660
Set Screw Size		M6	M8	M10	M12	M16	1/4	3/8	
Hex Head Key Size		3	4	5	6	8	1/8"	3/16"	
Tightening torque	(Nm)	6	12	25	50	100	8	25	
	(lb-in)	55	110	220	440	880	70	220	



CAUTION! Never use two set screws with one on top of the other in the same tapped hole.

5. Straight Bore with Interference Fit

- 5.1 Accurately measure the bore and shaft diameters to assure proper fit.
- 5.2 Install the key(s) in the shaft.
- 5.3 Heat the hub in an oven until the bore is sufficiently larger than the shaft.
- 5.4 275°F (135°C) is usually sufficient for carbon steel hubs. Do not exceed 400°F (205°C).
- 5.5 With the hub expanded, install it quickly on the shaft to the desired axial position. A pre-set axial stop device can be helpful.

Figure 5 – Shaft end to hub face measurement example.

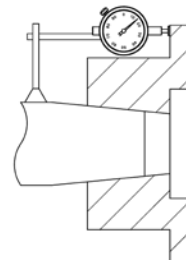
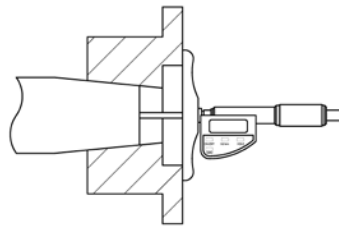

Figure 6 – Dial indicator placement for axial draw measurement example.

6. Taper Bore

- 6.1 Check for acceptable contact pattern between the hub and the shaft.
- 6.2 Put the hub on the shaft, keeping the keyways (if existing) aligned.
- 6.3 Lightly tap the face of the hub with a soft mallet. The resultant position will provide a starting point for the hub axial draw up.
- 6.4 Use a depth micrometer to measure the distance from the shaft end to the hub face, as shown in Figure 5. Record the dimension.
- 6.5 Mount a dial indicator to read axial hub advancement, as shown in Figure 6. Alternatively, the indicator can be positioned to contact the end of the hub. Set the indicator to “zero.”
- 6.6 Remove the hub and install the key(s) in the shaft.
- 6.7 Heat the hub in an oven until the bore is sufficiently larger than the shaft.
- 6.8 350°F (177°C) is usually sufficient for carbon steel hubs. Do not exceed 500°F (260°C).
- 6.9 Higher temperatures may be required for higher interference fit levels where alloy steel hubs may be encountered. A general rule to consider is that for every 160°F increase in temperature, steel will expand 0.001 inch for every inch of shaft diameter (or 0.029 mm/100°C). When calculating temperatures, also consider additional expansion to provide clearance and allow for a loss of heat and subsequent shrinkage during the handling process.
- 6.10 With the hub expanded, install it quickly on the shaft to the “zero” set point. Continue to advance the hub up the taper to the desired axial position, as defined by Rexnord’s customer. Use the indicator as a guide only. A pre-set axial stop device can be helpful.
- 6.11 Inspect the assembly to verify that the hub is properly positioned. Consult Rexnord if necessary.
- 6.12 Install any hub axial retention device (if any) in accordance with the equipment manufacturer’s specifications.

7. Shaft Alignment



ATTENTION! Soft foot – the equipment must rest flat on its base. If one or more feet of the machine are shorter, longer, or angled in some way to prevent uniform contact (a condition commonly known as “soft foot”) it must now be corrected.



ATTENTION! To improve the life of the coupling, the shafts must be aligned to minimize distortion of the flexing elements. Shaft alignment is required in the axial, parallel, and angular directions, with each of these values not to exceed the recommended ratings for the coupling and the alignment values shown in Table 3. Shaft alignment can be measured using various established methods, including Laser Alignment, Reverse Dial Indicator, and Rim and Face

Move the connected equipment to achieve acceptable alignment. When well aligned, the disc packs will be centered and approximately parallel to their mating flange faces and the flexing elements will have little visible waviness when viewed from the side.

As a guide, the maximum and minimum values for dimension “N” shown in Figure 7 are given in Table 3. These dimensions are suggested for initial installation. Additional capacity is available to compensate for thermal and structural equipment movement. Maximum axial capacity values for these couplings are also given in Table 3.

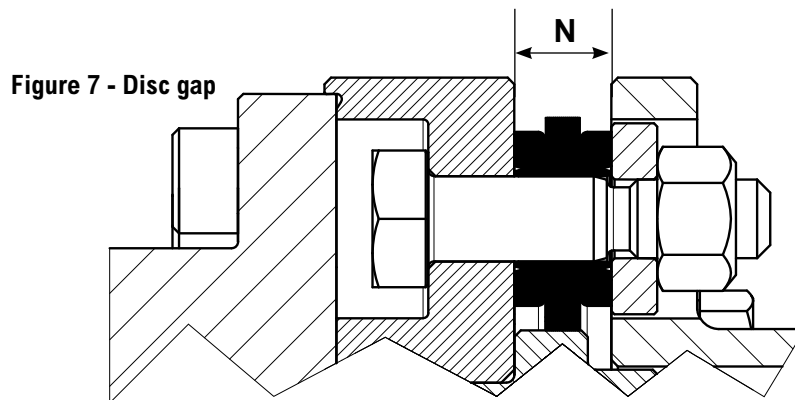

Table 3 shows installation limits for Angular and Parallel alignment. The Angular Alignment Total Indicator Reading value is the maximum difference between the measurements (X-Y) taken between opposite sides of the center spool flange and adapter flange as shown in Figure 8. The Parallel Alignment value “P” is the offset between the centers of the hubs, as shown in Figure 9. If parallel offset is measured by rotating the hubs with a dial indicator on the outside diameter, the total indicated reading should be divided by (2) to calculate “P”.

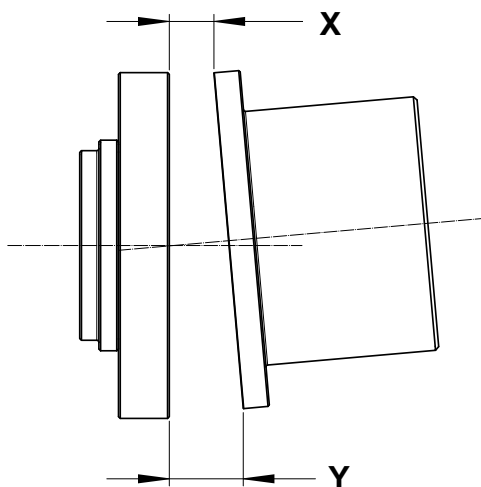

Figure 8 - Angular Misalignment

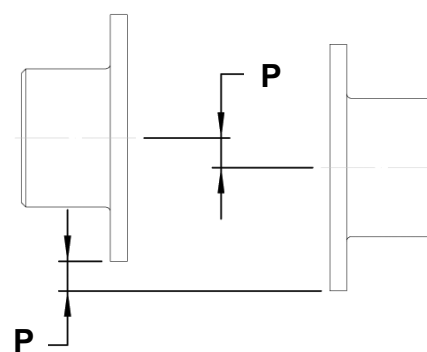

Figure 9 - Parallel Misalignment

Table 3 — Alignment Values

XTSR 71 Size	"A" Dimension		"A" Dimension		"N" Dimension				"C" Length (distance between hub flanges)		Installation Axial Limits +/-		Axial Capacity +/-		Recommended Installation Limits***							
	Std. Hub		XL Hub		Min.	Max.	Min.	Max.	(in)	(mm)	(in)	(mm)	(in)	(mm)	Parallel Misalignment				Angular Misalignment Between Hubs Installation (X-Y) Standard Hub	Angular Misalignment Between Hubs Installation (X-Y) XL Hub		
	Parallel Alignment Total Indicator Reading (TIR*)		Installation Limit Parallel Offset "P"***		(in)		(mm)															
	(in)	(mm)	(in)	(mm)	(in)	(in)	(mm)	(mm)	(in)	(mm)	(in)	(mm)	(in)	(mm)	(in)	(mm)	(in)	(mm)	(in)	(mm)		
494	2.77	70.0	3.36	85.0	0.33	0.35	8.3	8.8	3.50	88.9	0.012	0.30	0.024	0.6	0.035	0.89	0.018	0.44	0.004	0.10	0.004	0.10
									3.75	95.3					0.038	0.95	0.019	0.48				
									5.00	127.0					0.050	1.27	0.025	0.64				
									3.94	100.0					0.039	1.00	0.020	0.50				
									5.51	140.0					0.055	1.40	0.028	0.70				
644	3.36	85.0	---	---	0.33	0.35	8.3	8.8	3.50	88.9	0.017	0.43	0.033	0.9	0.035	0.89	0.018	0.44	0.004	0.10	---	---
									3.75	95.3					0.038	0.95	0.019	0.48				
									5.00	127.0					0.050	1.27	0.025	0.64				
									3.94	100.0					0.039	1.00	0.020	0.50				
									5.51	140.0					0.055	1.40	0.028	0.70				
726	3.74	95.0	4.25	108.0	0.33	0.35	8.3	8.8	3.50	88.9	0.026	0.65	0.051	1.3	0.035	0.89	0.018	0.44	0.005	0.13	0.006	0.15
									3.75	95.3					0.038	0.95	0.019	0.48				
									4.38	111.1					0.040	1.02	0.020	0.51				
									5.00	127.0					0.050	1.27	0.025	0.64				
									3.94	100.0					0.039	1.00	0.020	0.50				
826	4.25	108.0	5.08	129.0	0.36	0.38	9.1	9.6	3.50	88.9	0.030	0.75	0.059	1.5	0.035	0.89	0.018	0.44	0.006	0.15	0.007	0.18
									3.75	95.3					0.038	0.95	0.019	0.48				
									4.38	111.1					0.040	1.02	0.020	0.51				
									5.00	127.0					0.050	1.27	0.025	0.64				
									3.94	100.0					0.039	1.00	0.020	0.50				
996	5.08	129.0	5.51	140.0	0.37	0.39	9.3	9.9	3.50	88.9	0.035	0.90	0.070	1.8	0.035	0.89	0.018	0.44	0.007	0.18	0.008	0.20
									3.75	95.3					0.038	0.95	0.019	0.48				
									4.38	111.3					0.040	1.02	0.020	0.51				
									5.00	127.0					0.050	1.27	0.025	0.64				
									3.94	100.0					0.039	1.00	0.020	0.50				
1088	5.51	140.0	6.54	166.0	0.40	0.42	10.1	10.7	3.50	88.9	0.025	0.65	0.051	1.3	0.035	0.89	0.018	0.44	0.005	0.13	0.006	0.15
									3.75	95.3					0.038	0.95	0.019	0.48				
									4.38	111.3					0.040	1.02	0.020	0.51				
									5.00	127.0					0.050	1.27	0.025	0.64				
									3.94	100.0					0.039	1.00	0.020	0.50				
1298	6.54	166.0	7.83	199.0	0.50	0.52	12.6	13.3	3.50	88.9	0.031	0.80	0.061	1.6	0.035	0.89	0.018	0.44	0.006	0.15	0.008	0.20
									3.75	95.3					0.038	0.95	0.019	0.48				
									4.38	111.3					0.040	1.02	0.020	0.51				
									5.00	127.0					0.050	1.27	0.025	0.64				
									3.94	100.0					0.039	1.00	0.020	0.50				
1548	7.83	199.0	8.66	220.0	0.57	0.59	14.4	5.1	3.50	88.9	0.037	0.90	0.073	1.8	0.035	0.89	0.018	0.44	0.008	0.20	0.008	0.20
									3.75	95.3					0.038	0.95	0.019	0.48				
									4.38	111.3					0.040	1.02	0.020	0.51				
									5.00	127.0					0.050	1.27	0.025	0.64				
									3.94	100.0					0.039	1.00	0.020	0.50				
1698	8.66	220.0	9.66	245.4	0.61	0.64	15.4	16.2	3.50	88.9	0.040	1.00	0.080	2.0	0.035	0.89	0.018	0.44	0.008	0.20	0.009	0.23
									3.75	95.3					0.038	0.95	0.019	0.48				
									4.38	111.3					0.040	1.02	0.020	0.51				
									5.00	127.0					0.050	1.27	0.025	0.64				
									3.94	100.0					0.039	1.00	0.020	0.50				
1928	9.66	245.4	10.39	264.0	0.66	0.69	16.7	17.4	3.50	88.9	0.046	1.15	0.091	2.3	0.035	0.89	0.018	0.44	0.009	0.23	0.010	0.25
									3.75	95.3					0.038	0.95	0.019	0.48				
									4.38	111.3					0.040	1.02	0.020	0.51				
									5.00	127.0					0.050	1.27	0.025	0.64				
									3.94	100.0					0.039	1.00	0.020	0.50				
2068	10.39	264.0	11.44	290.5	0.71	0.74	18.0	18.8	3.50	88.9	0.049	1.25	0.097	2.5	0.035	0.89	0.018	0.44	0.010	0.25	0.011	0.28
									3.75	95.3					0.038	0.95	0.019	0.48				
									4.38	111.3					0.040	1.02	0.020	0.51				
									5.00	127.0					0.050	1.27	0.025	0.64				
									3.94	100.0					0.039	1.00	0.020	0.50				
2278	11.44	290.5	12.32	313.0	0.74	0.77	18.8	19.5	3.50	88.9	0.054	1.35	0.107	2.7	0.035	0.89	0.018	0.44	0.011	0.28	0.012	0.30
									3.75	95.3					0.038	0.95	0.019	0.48				
									4.38	111.3					0.040	1.02	0.020	0.51				
									5.00	127.0					0.050	1.27	0.025	0.64				
									3.94	100.0					0.039	1.00	0.020	0.50				
2468	12.32	313.0	13.58	345.0	0.79	0.82	20.1	20.8	3.50	88.9	0.058	1.50	0.116	3.0	0.035	0.89	0.018	0.44	0.012	0.30	0.013	0.33
									3.75	95.3					0.038	0.95	0.019	0.48				
									4.38	111.3					0.040	1.02	0.020	0.51				
									5.00	127.0					0.050	1.27	0.025	0.64				
									3.94	100.0					0.039	1.00	0.020	0.50				
2698	13.58	345.0	15.00	381.0	0.91	0.94	23.0	23.9	3.50	88.9	0.064	1.60	0.127	3.2	0.035	0.89	0.018	0.44	0.013	0.33	0.014	0.36
									3.75	95.3					0.038	0.95	0.019	0.48				
									4.38	111.3					0.040	1.02	0.020	0.51				
									5.00	127.0					0.050	1.27	0.025	0.64				
									3.94	100.0					0.039	1.00	0.020	0.50				
2888	15.00	381.0	15.94	405.0	0.97	1.00	24.7	25.4	3.50	88.9	0.068	1.75	0.136	3.5	0.035	0.89	0.018	0.44	0.014	0.36	0.015	0.38
									3.75	95.3					0.038	0.95	0.019	0.48				
									4.38	111.3					0.040	1.02	0.020	0.51				
									5.00	127.0					0.050	1.27	0.025	0.64				
									3.94	100.0					0.039	1.00	0.020	0.50				
3058	15.94	405.0	17.20	437.0	0.97	1.01	24.7	25.6	3.50	88.9	0.072	1.85	0.144	3.7	0.035	0.89	0.018	0.44	0.015	0.38	0.017	0.43
									3.75	95.3					0.038	0.95	0.019	0.48				
									4.38	111.3					0.040	1.02	0.020	0.51				
									5.00	127.0					0.050	1.27	0.025	0.64				
									3.94	100.0					0.039	1.00	0.020	0.50				
3358	17.20	437.0	18.98	482.0	1.06	1.09	27.0	27.7	3.50	88.9	0.079	2.00	0.158	4.0	0.035	0.89	0.018	0.44	0.017	0.43	0.018	0.46
									3.75	95.3					0.038	0.95	0.019	0.48				
									4.38	111.3					0.040	1.02	0.020	0.51				
									5.00	127.0					0.050	1.27	0.025	0.64				
									3.94	100.0					0.039	1.00	0.020	0.50				
3668	18.98	482.0	19.80	503.0	1.18	1.21	29.9	30.8	3.50	88.9	0.087	2.20	0.173	4.4	0.035	0.89	0.018	0.44	0.018	0.46	0.019	0.48
									3.75	95.3					0.038	0.95	0.019	0.48				
									4.38	111.3					0.040	1.02	0.020	0.51				
									5.00	127.0					0.050	1.27	0.025	0.64				
									3.94	100.0					0.039	1.00	0.020	0.50				
3908	19.80	503.0	20.83	529.0	1.18	1.21	29.9	30.8	3.50	88.9	0.093	2.35	0.185	4.7	0.035	0.89	0.018	0.44	0.019	0.48	0.020	0.51
									3.75	95.3					0.038	0.95	0.019	0.48				
									4.38	111.3					0.040	1.02	0.020	0.51				
									5.00	127.0					0.050	1.27	0.025	0.64				
									3.94	100.0					0.039	1.00	0.020	0.50				
4178	20.83	529.0	23.94	608.0	1.25	1.30	31.9	33.0	3.50	88.9	0.099	2.50	0.197	5.0	0.035	0.89	0.018	0.44	0.020	0.51	0.023	0.58
									3.75	95.3					0.038	0.95	0.019	0.48				
									4.38	111.3					0.040	1.02	0.020	0.51				
									5.00	127.0					0.050	1.27	0.025	0.64				
									3.94	100.0					0.039	1.00	0.020	0.50				
4588	23.94	608.0	25.51	648.0	1.40	1.43																

8. Final Assembly



XTSR71 couplings are delivered from the factory with a fully assembled center member subassembly with locknuts tightened at the factory to the torque specified in Table 5. The center member subassembly is ready for field installation, and we recommend that you do not disassemble it (unless you are replacing the disc packs).

Verify that the hubs have been mounted as shown in Figure 4, to provide the correct “C” length (defined in Table 1). The “C” length is the distance measured between the faces of the two hub flanges.

Due to the hub-to-adapter piloting feature, the center member subassembly must be compressed to allow it to be slipped between the two end hubs.

Use the hub to adapter cap screws (provided) as defined in Figure 2 and Table 4 to compress the center member assembly by inserting them through the holes in the flanges of the center spool and threading them into the adapter tapped holes as shown in Figure 10.

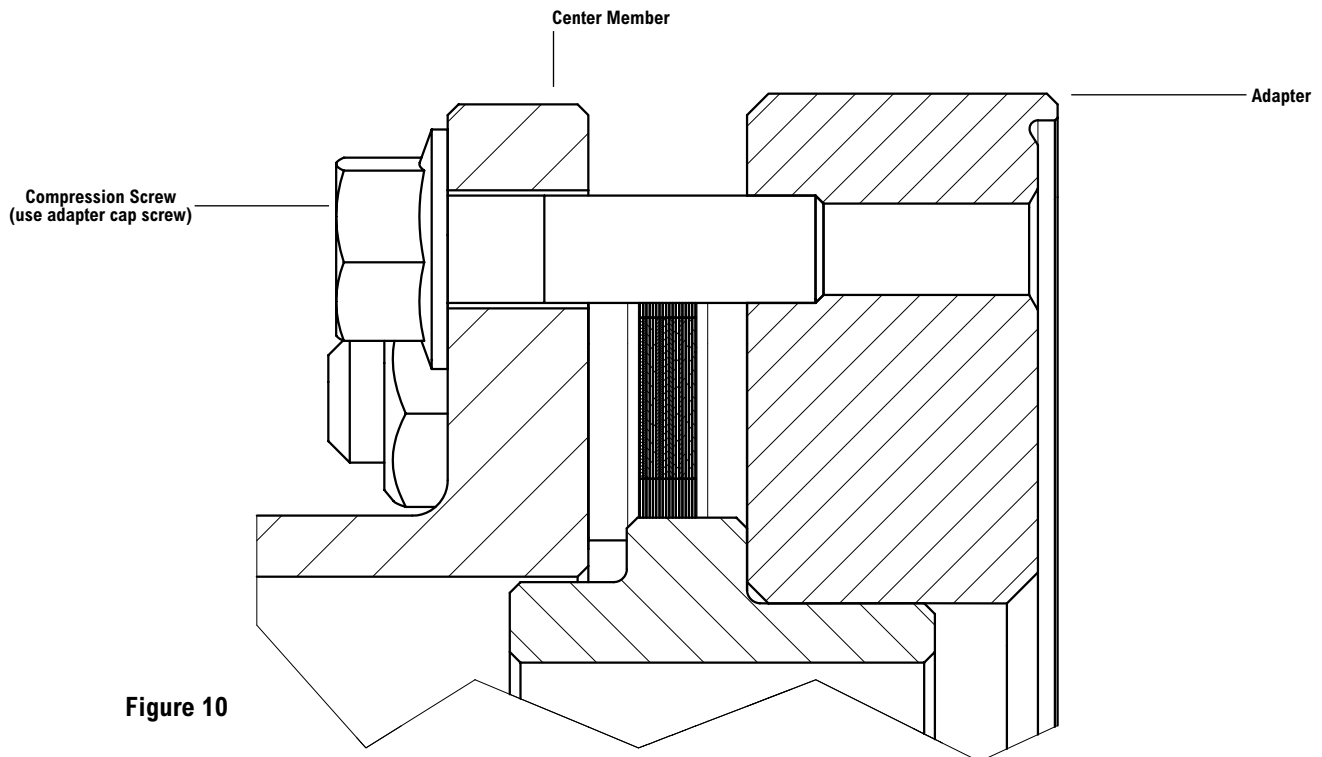

Tighten the cap screws equally to compress both ends only enough to allow the center member subassembly to fit between the hubs (do not tighten more than necessary to provide clearance for assembly).

- 8.1 Make sure that the adapter and the hub flange face and pilots are free from foreign material, nicks and burrs to allow for proper pilot seating.
- 8.2 Place the compressed center member between the coupling hubs, lining up the tapped holes in the adapter with the cap screw clearance holes in the hub. If the coupling was assembly balanced, also align any match marks.
- 8.3 Remove the cap screws from the spacer flange to adapter, allowing the hub outside diameter to make contact with the pilot diameter of the adapter.
- 8.4 Lubricate the cap screw threads and insert the cap screws through the hub flange clearance holes and into the mating threaded holes in the adapter. Tighten each cap screw to the torque as listed in Table 4.

For further help with the installation or alignment consult Rexnord.



Note: All bolts and cap screw threads must be lubricated prior to assembly. A clean motor oil is recommended. Do not use lubricants containing molybdenum disulfide or greases.



PRECAUTION

Remove any dust deposits from the coupling components and the coupling elements in an appropriate way for explosive environments.

Table 4 — Cap Screw Tightening Torque

XTSR71 Coupling Size	"A" Dimension Std. Hub		Flange Hex Head Cap Screw-Standard Hub				"A" Dimension XL Hub		Flange Hex Head Cap Screw-XL Hub			
			Cap Screw Size	Torque		Wrench Size (mm)			Cap Screw Size	Torque		Wrench Size (mm)
	(in)	(mm)		(mm)	(ft-lb)		(Nm)	(in)		(mm)	(mm)	
494	2.77	70.0	M5x20	6.3	8.5	8	3.36	85.0	M5x20	6.3	8.5	8
644	3.36	85.0	M5x20	6.3	8.5	8	---	---	---	---	---	---
726	3.74	95.0	M6x20	12.3	16.7	10	4.25	108.0	M6x20	12.3	16.7	10
826	4.25	108.0	M6x20	12.3	16.7	10	5.08	129.0	M8x25	27	36	13
996	5.08	129.0	M8x25	27.0	36	13	5.51	140.0	M6x25	12.3	16.7	10
1088	5.51	140.0	M6x25	12.3	16.7	10	6.54	166.0	M8x30	27	36	13
1298	6.54	166.0	M8x30	27	36	13	7.83	199.0	M10x35	51.0	69	15
1548	7.83	199.0	M10x35	51	69	15	8.66	220.0	M10x40	51.0	69	15
1698	8.66	220.0	M10x40	51	69	15	9.66	245.4	M12x40	92.0	124	16
1928	9.66	245.4	M12x40	92	124	16	10.39	264.0	M12x40	92.0	124	16
2068	10.39	264.0	M12x40	92	124	16	11.44	290.5	M12x50	92.0	124	16
2278	11.44	290.5	M12x50	92	124	16	12.32	313.0	M14x50	142	193	18
2468	12.32	313.0	M14x50	142	193	18	13.58	345.0	M12x60	92.0	124	16
2698	13.58	345.0	M12x60	92	124	16	15.00	381.0	M14x70	142	193	18
2888	15.00	381.0	M14x70	142	193	18	15.94	405.0	M14x70	142	193	18
3058	15.94	405.0	M14x70	142	193	18	17.20	437.0	M16x70	218	295	21
3358	17.20	437.0	M16x70	218	295	21	18.98	482.0	M16x80	218	295	21
3668	18.98	482.0	M16x80	218	295	21	19.80	503.0	M16x80	218	295	21
3908	19.80	503.0	M16x80	218	295	21	20.83	529.0	M16x80	218	295	21
4178	20.83	529.0	M16x80	218	295	21	23.94	608.0	M20x90	427	579	27
4588	23.94	608.0	M20x90	427	579	27	25.51	648.0	M20x100	427	579	27
4918	25.51	648.0	M20x100	427	579	27	26.69	678.0	M20x110	427	579	27
5258	26.69	678.0	M20x110	427	579	27	---	---	---	---	---	---

Note:

1. These torque values are approximate for cap screws with lubricated threads.

9. Disc Pack Replacement

If it becomes necessary to replace the disc packs, it can be done as follows.



Note: The XTSR71 center member subassemblies have their locknuts factory tightened. On center member subassemblies where the spacer length is short and wrench access is limited, special wrenches are used to tighten the locknuts. Consult Rexnord for assistance in obtaining these special wrenches.

- 9.1 Remove the center member subassembly by removing all cap screws from hubs to compress the center member assembly by inserting them through the holes in the flanges of the center spool and threading them into the adapter tapped holes as shown in Figure 10 and dropping the center member assembly out from between the hubs. There are jacking screw tapped holes in each end hub to disengage the pilots between the hubs and adapters, using the hub to adapter cap screws as defined in Table 4.
- 9.2 Remove all locknuts, bolts, bushings, and disc packs. Special wrenches may be required. Clean the two adapters and the center spool, removing any nicks and burrs. See Figure 2. Install the new disc packs to the adapters first.



Match marks (if applied at assembly balance) must be in-line to maintain balance integrity.

- 9.3 Install the disc packs to the adapter first so that the washer heads of the disc pack line up with the bolt holes in the adapter as shown in Figure 11A. Insert the bolts through the adapter bolt holes and disc pack.

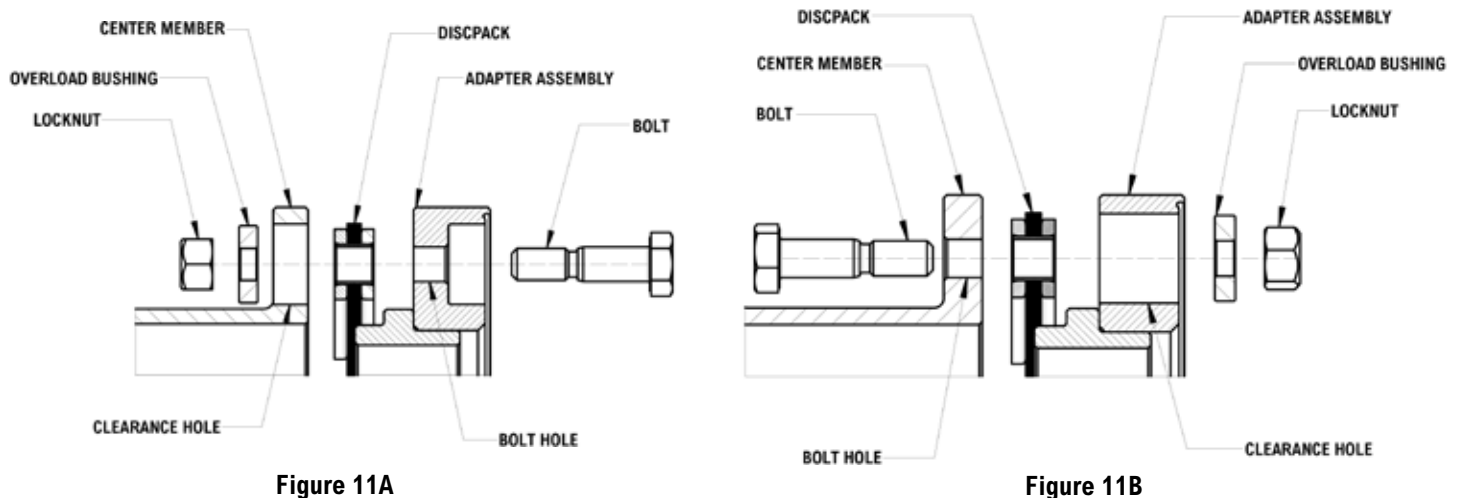

Figure 11A

Figure 11B

- 9.4 Install an overload bushing onto each bolt, as shown on Figure 11A and 11B.
- 9.5 Apply a clean motor oil to the bolt threads and install a locknut on each bolt. Slightly tighten all locknuts using an alternating progressive pattern as shown in Figures 13 and 14, making sure all the bolts are fully seated. At this stage you will only be working with half of the bolts on the disc pack. Now tighten each locknut to the appropriate torque value shown in Table 5, using incremental torque in a progressive alternating pattern as shown in Figures 13 and 14.



All bolt threads must be lubricated prior to assembly. A clean motor oil is recommended. Do not use lubricants containing molybdenum disulfide or greases.

- 9.6 Position center member against disc pack aligning the clearance holes on the center member to the installed bolts on the adapter to disc pack joint.
- 9.7 Insert all the remaining bolts through the center member bolt holes and disc pack as shown in Figure 11B.
- 9.8 Install an overload bushing onto each bolt, as shown on Figure 11A and 11B.
- 9.9 Apply a clean motor oil to the bolt threads and install a locknut on each bolt.
- 9.10 Slightly tighten remaining locknuts using an alternating progressive pattern as shown in Figures 13 and 14, making sure the pack is not distorted and all the bolts are fully seated. Now tighten each locknut to the appropriate torque value shown in Table 5, using an incremental torque in a progressive alternating pattern as shown in Figures 13 and 14.
- 9.11 Proceed to install the center member subassembly as outlined in the Final Assembly section 8.



When possible, it is recommended that all locknuts have their tightening torque checked after several hours of initial operation.

For spare replacement parts, see Table 1.

10. Center Member Assembly Balance Setup

When center member assembly balance is required, it can be done as follows.

- 10.1 If service work or component replacement was done to center member assembly follow instructions in section 9 for proper reassembly.
- 10.2 With a fully assembled spacer assembly, use 6 on a 6 bolt and 8 on an 8 bolt disc pack, the adapter hub to adapter cap screws provided as defined in Figure 2 and Table 4 to compress the center member assembly by inserting them through the holes in the flanges of the center spool and threading them into the adapter tapped holes as shown in Figure 10.
- 10.3 Repeat instruction 10.2 on opposite flange to adapter. Both ends of the spacer assembly will need to be compressed to rigidize the assembly for proper balance.
- 10.4 Use a progressive tightening pattern until the spacer flange is pressed against the raised boss of the protruded anti-flail feature of the adapter as shown in Figure 12 below. Use the same process on both sides of the spacer assembly.

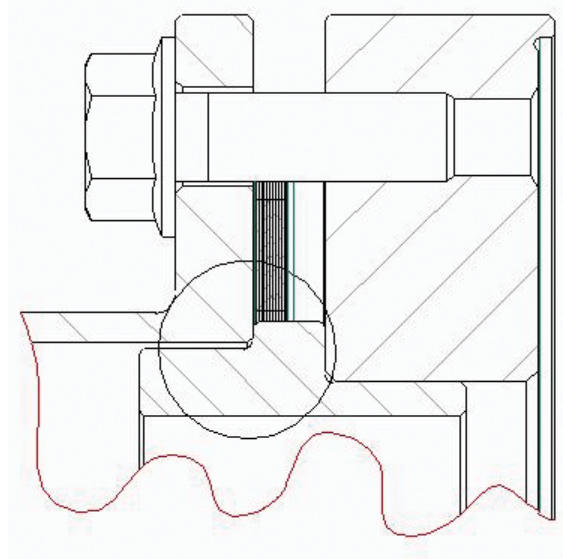

Figure 12

- 10.5 With both sides of the assembly compressed against the raised boss, the center assembly is rigidized for balancing.
- 10.6 Inspect and remove any burrs on outside edges of spacer and adapter to prevent potential balance errors.
- 10.7 Perform balancing procedure per your company requirements.
- 10.8 Follow section 8 Final Assembly to install the center assembly to the coupling.
- 10.9 After removing rigidizing hardware, the overall length of the spacer assembly may be shorter than originally designed. This does not detrimentally affect the coupling, which can be assembled to the hubs according to section 8 Final Assembly.



The adapter hub hardware used in compressing the center member assembly is weight balanced hardware for the complete coupling assembly. Keep hardware separated to the adapter hub that it originally came with and take care not to damage any of the hardware.

Table 5 — Lock Nut Tightening Torque

XTSR71 Coupling Size	"A" Dimension Std. Hub		Locknut			
			Bolt Size (mm)	Torque		Wrench Size (in)
	(in)	(mm)		(ft-lb)	(Nm)	
494	2.77	70.0	M5	4.7	6.4	8
644	3.36	85.0	M5	4.7	6.4	8
726	3.74	95.0	M5	4.7	6.4	8
826	4.25	108.0	M6	8.1	11	11
996	5.08	129.0	M8	18	24	14
1088	5.51	140.0	M8	18	24	14
1298	6.54	166.0	M10	39	53	18
1548	7.83	199.0	M12	66	90	21
1698	8.66	220.0	M14	110	150	22
1928	9.66	245.4	M16	162	220	24
2068	10.39	264.0	M18	236	320	27
2278	11.44	290.5	M20	266	360	30
2468	12.32	313.0	M22	384	520	32
2698	13.58	345.0	M24	575	780	36
2888	15.00	381.0	M27	885	1200	41
3058	15.94	405.0	M27	885	1200	41
3358	17.20	437.0	M30	1200	1600	46
3668	18.98	482.0	M33	1500	2000	50
3908	19.80	503.0	M33	1500	2000	50
4178	20.83	529.0	M36	2100	2800	55
4588	23.94	608.0	M42	3200	4400	65
4918	25.51	648.0	M45	4100	5600	70
5258	26.69	678.0	M48	4900	6700	75

Notes:

1. These torque values are approximate for steel bolts with lubricated threads.
2. Bolts should be held from rotating while the locknuts are tightened to the values shown. Do not tighten the fastener by rotating the bolt head.

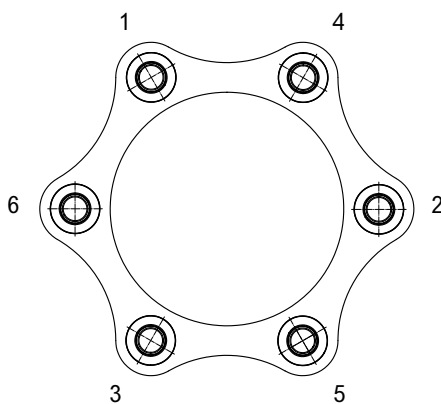

Figure 13

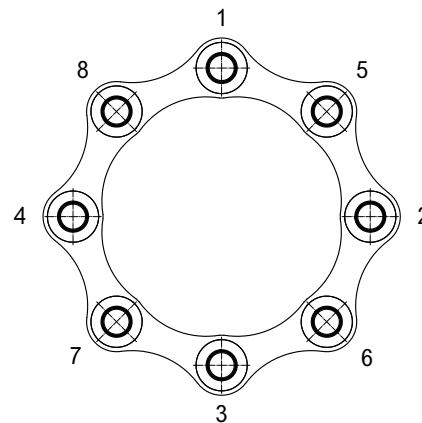

Figure 14